

FEATURES

- Plastic package has Underwriters Laboratory Flammability Classification 94V-0
- Metal silicon junction ,majority carrier conduction
- Guard ring for overvoltage protection
- Low power loss ,high efficiency
- High current capability ,Low forward voltage drop
- High surge capability
- For use in low voltage ,high frequency inverters, free wheeling ,and polarity protection applications
- Dual rectifier construction
- High temperature soldering guaranteed:260° C/10 seconds,, 0.25"(6.35mm)from case
- Component in accordance to RoHS 2002/95/EC and WEEE 2002/96/EC

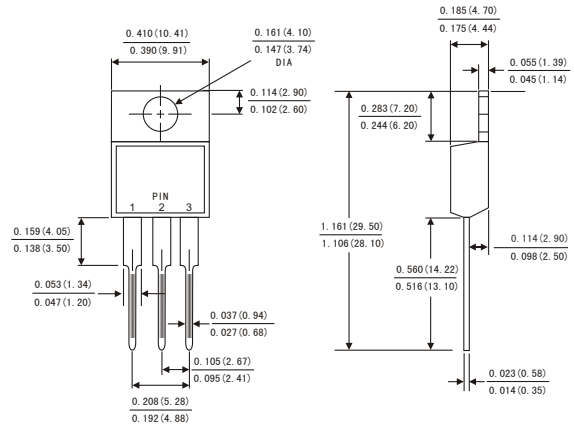

TO-220AB



MECHANICAL DATA

- Case: JEDEC TO-220AB molded plastic body
- Terminals: Lead solderable per MIL-STD-750,method 2026
- Polarity: As marked
- Mounting Position: Any
- Weight: 0.08ounce, 2.24 grams

Dimensions in inches and (millimeters)

MAXIMUM RATINGS AND ELECTRICAL CHARACTERISTICS

(Ratings at 25°C ambient temperature unless otherwise specified ,Single phase ,half wave ,resistive or inductive load. For capacitive load,derate by 20%.)

	Symbols	MBR 2020CT	MBR 2030CT	MBR 2040CT	MBR 2050CT	MBR 2060CT	MBR 2080CT	MBR 20100CT	MBR 20150CT	MBR 20200CT	Units	
Maximum repetitive peak reverse voltage	V _{RRM}	20	30	40	50	60	80	100	150	200	Volts	
Maximum RMS voltage	V _{RMS}	14	21	28	35	42	56	70	105	140	Volts	
Maximum DC blocking voltage	V _{DC}	20	30	40	50	60	80	100	150	200	Volts	
Maximum average forward rectified current(see Fig.1)	Per leg										10.0	Amps
	Total device										20.0	
Peak forward surge current 8.3ms single half sine-wave superimposed on rated load (JEDEC method)	I _{FSM}										200.0	Amps
Maximum instantaneous forward voltage at 20.0 A	V _F	0.60		0.75		0.85		0.90		0.95	Volts	
Maximum instantaneous reverse current at rated DC blocking voltage(Note 1)	T _c = 25°C										0.2	mA
	T _c = 125°C	30			50							
Typical thermal resistance (Note 2)	R _{θJC}										3.0	°C/W
Operating junction temperature range	T _J										-65 to +150	°C
Storage temperature range	T _{STG}										-65 to +150	°C

- Notes: 1.Pulse test: 300 μs pulse width,1% duty cycle
- 2.Thermal resistance from junction to case

FIG.1-FORWARD CURRENT DERATING CURVE

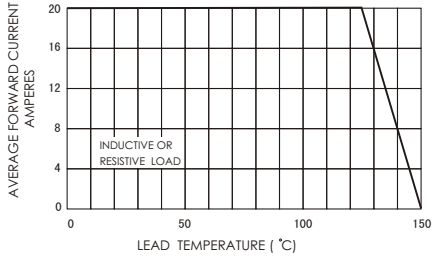

FIG.2-MAXIMUM NON-REPETITIVE PEAK FORWARD SURGE CURRENT

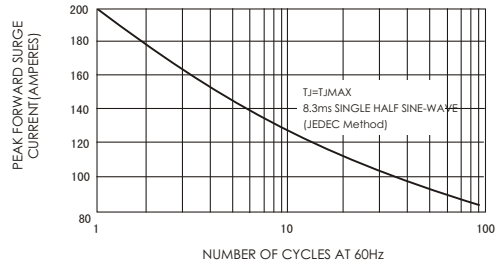

FIG.3-TYPICAL INSTANTANEOUS FORWARD CHARACTERISTICS

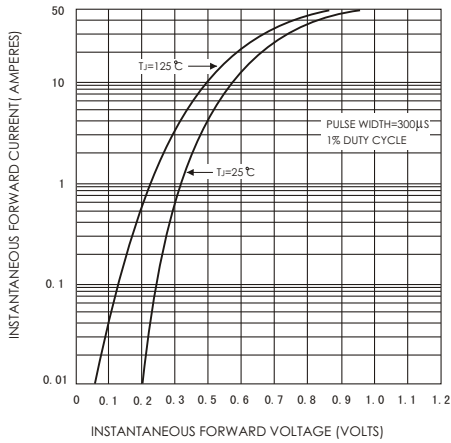

FIG.4-TYPICAL REVERSE CHARACTERISTICS

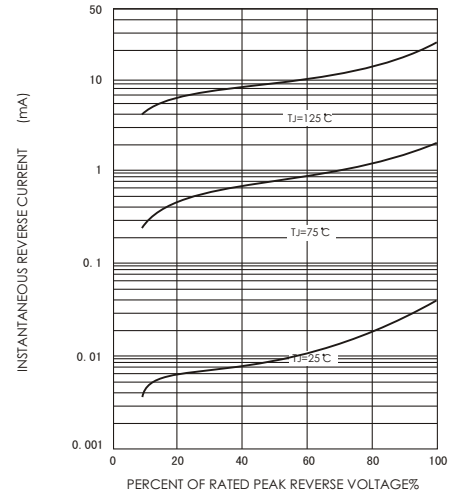

FIG.5-TYPICAL JUNCTION CAPACITANCE

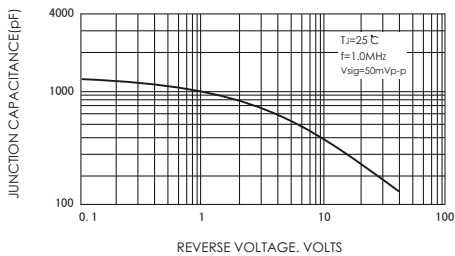

FIG.6-TYPICAL TRANSIENT THERMAL IMPEDANCE

